

# **4983A - AdVantis Platform**

## **AC-30L**

GS- 415-00 Rev. A

CR # 1010463

Issued 3/2007

## **General Specification**

Reference Assy. #50204002

**Table of Contents**

Introduction ..... 5

    Concept ..... 5

    Construction..... 5

    Features..... 5

        Welded Base Frame ..... 5

        Leadscrew Positioning System ..... 6

        Lightning Placement Head ..... 6

        Nozzles ..... 6

        AdVantis AC-30L Camera Systems ..... 6

        On-The-Head Cameras ..... 7

        Fiducial Inspection Camera ..... 7

        High Capacity Nozzle Changer ..... 7

        Staged Board Handling ..... 7

        Board Support..... 7

        PrecisionPro™ Feeder Interface ..... 8

        18 Slot Modular Feeder Banks ..... 8

        AdVantis AC-30L Platform Machine Control System Architecture ..... 8

        Microsoft Windows 2000 Operating System ..... 8

UPS+ (Universal Platform Software +)..... 9

    Basic Features of UPS+..... 9

        Expanded System Security ..... 9

        Built-in Links to Universal.com ..... 10

        On-line Documentation - VOYAGER Operation..... 10

        Detailed Event Messages ..... 10

        Detailed Error and Warning Messages ..... 11

        Advanced Product Editor ..... 11

        UPS+ Component Database..... 11

        Customizable User Interface Templates for the Following User Levels: ..... 12

        Operator Interface and Production Setup Tools..... 12

        Auto-Pick Update and Auto-Z Update ..... 12

        Skip Component Quick Bypass..... 12

        True-to-scale Configuration Graphics ..... 13

        Management Information System ..... 13

        Diagnostic Tools ..... 13

        New AC-30L Supported Features ..... 14

        Recommended Off-line PC Configuration: ..... 14

        Minimum Off-line PC Configuration:..... 14

New Product Introduction Software (NPI) ..... 15

    Feeder Inspection ..... 15

    Fiducial Inspection ..... 15

    Pre-placement Inspection ..... 15

    Circuit / Offset Inspection ..... 15

    Board Population ..... 15

    Post-placement Inspection..... 15

Optional Equipment ..... 16

    Input Power..... 16

    CE Compliance Input Filter ..... 16

    Feeders..... 16

        Feeder Inputs..... 16

    Feeder Bank Changing ..... 17

        Feeder Bank Change Cart ..... 17

        Removable Feeder Bank Storage Table ..... 17

        Feeder Setup Cart ..... 17

        Docking Module ..... 17

        Recommended Configuration for an individual Bank or Machine ..... 18

        Feeder Storage Cart ..... 18

        Tape Scrap Bin ..... 18

        Low Profile Tape Scrap Bin ..... 18

        Component Reject Bin ..... 18

        Scrap Tape Cutter..... 18

        Component Reject Station ..... 19

Board Handling .....	19
Long Board Kits .....	19
Optional Board Support Systems .....	19
Calibration .....	19
MCCM Calibration Fixtures .....	19
Auto-Trim/MMI Kit .....	19
Spare Parts and Tool Kits .....	20
Spare Parts Kit .....	20
Basic Spare Parts Kit .....	20
Chemical and Lubrication .....	20
Lightning Head .....	20
Spindle Kit .....	20
Pneumatic Filter Kit .....	20
Tool Kits .....	20
AdVantis Tool Kit .....	20
Lightning Head Tool Kit .....	21
Installation Kits .....	21
Platform Installation Kit .....	21
GSMA / AdVantis Install Tool Kit .....	21
GSMA Add-on Install Kit .....	21
Software .....	22
Machine Level Software Options .....	22
GEM .....	22
Platform Traceability .....	22
Bar Code Product Changeover .....	22
Platform Setup Validation (PSV) Option .....	22
Line Level Software Options: .....	22
Specifications .....	23
Installation Specifications .....	23
Installation Considerations .....	23
Machine Dimensions: AdVantis AC-30L .....	23
AdVantis AC-30L Platform Installation Hardware: .....	23
Floor Loading Requirements .....	23
Service Requirements .....	24
Service Requirements .....	25
Pneumatics (clean air) .....	25
Environmental Requirements .....	25
AdVantis AC-30L Platform Footprint: .....	26
Aisle Considerations for Use of Feeder Carts: .....	27
AdVantis Positioning System Specifications .....	28
Placement Head .....	29
Lightning Head Specifications .....	29
Component Handling .....	29
On-The-Head-Camera Specifications .....	30
Nozzles .....	31
Lightning Nozzles .....	31
Fiducial Specifications .....	32
Global and Local Fiducial Shapes and Dimensions .....	32
Board Handling Specifications .....	33
Board Specifications – Standard Board Handling .....	33
Board Clearance .....	34
Board Handling Dimensions .....	34
Board Support Specifications .....	34
Long Board Kit .....	34
Performance Capability .....	35
Performance .....	35
Appendix A .....	36
Model Specifications Summary .....	36
Appendix B .....	37
Bar Code Types .....	37
Appendix C .....	38
Acceptance Criteria .....	38

Field Acceptance Kit ..... 41  
Contact Information ..... 42

## Glossary of Acronyms and Specialized Terms

Acronym/Term	Meaning
AC	Alternating Current: type of electrical power generation
APE	Advanced Product Editor (Universal brand name)
ASCII	American National Standard Code for Information Interchange
AWG	American Wire Gauge: wire size standard
CAD	Computer-Aided Design
CD-ROM	Compact Disc-Read Only Memory
CE	Conformité Européenne: European safety standard
CFM	Cubic Feet per Minute: measurement of air flow
CPH	Components per Hour
CTA	Component Transfer Assembly
DC	Direct Current: type of electrical power generation
DVD	Digital Video Disc
EIA	Electronic Industries Alliance: Industry Standards Organization
GEM	Generic Equipment Model
GS	General Specification (Universal brand name)
GUI	Graphical User Interface
HSMS	High Speed SECS Message Service: implements SECS2 messaging over a network link
Hz	Hertz (cycles per second): measurement of electrical frequency
I/O	Input/Output
IEC	International Electrotechnical Commission: Industry Standards Organization
IP	Index of Protection: resistance of machine to contamination by foreign objects
IPC	IPC: Industry Standards Organization
JEDEC	JEDEC Solid State Technology Association: Industry Standards Organization
LED	Light Emitting Diode: electrical component
MMIT	Mini Machine Interface Translator (VME to I/O bus)
P.C.	Personal Computer
PCB (or PC board)	Printed Circuit Board
PPM	Parts Per Million: measurement of machine performance
RFQ	Request For Quote
SCFM	Standard Cubic Feet per Minute: measurement of airflow
SECS	Semiconductor Equipment Communications Standard: interface between host computer and assembly machines
SEMI	Semiconductor Equipment & Materials International
SMC	Surface Mount Components
SMEMA	Surface Mount Equipment Manufacturers Association
TCP/IP	Transfer Control Protocol/Internet Protocol: network communication protocol
UICS	Universal Instruments Control Software (Universal brand name)
UPS	Universal Platform Software (Universal brand name)
VA	Volt-Amps: measurement of electrical power consumption
VAC	Volts Alternating Current
VDC	Volts Direct Current
VGA	Video Graphics Array: type of CRT monitor standard
VME®	Versa Module Eurocard (Motorola brand name): industry standard for 32-bit computer bus
VRM	Variable Reluctance Motor

All specifications are subject to periodic review and may be changed without notice. Illustrations may not be drawn to scale.

Universal Instruments Corporation, 2003. All rights reserved.

Universal, the circle "U", the Universal logo, GSM Platform and Applied ConveyorEngineering are registered trademarks for products and services of Universal Instruments Corporation. GSM1, GSM2, GSM Advantis Platform, Advantis, Lightning, Magellan, and FlexJet are trademarks for products of Universal Instruments Corporation.

Ethernet is a trademark of Xerox Corporation. Intel is a trademark of Intel Corporation.

# Introduction

## Concept

---

The AdVantis AC-30L is a high speed modular mounter, specifically engineered for application flexibility and long term reliability. The AdVantis AC-30L provides an attractive cost per placement for small components, yet is equipped to manage the accuracy and repeatability demands of emerging technologies. This Platform is an ideal high speed machine with a component range far superior to traditional chipshooters.

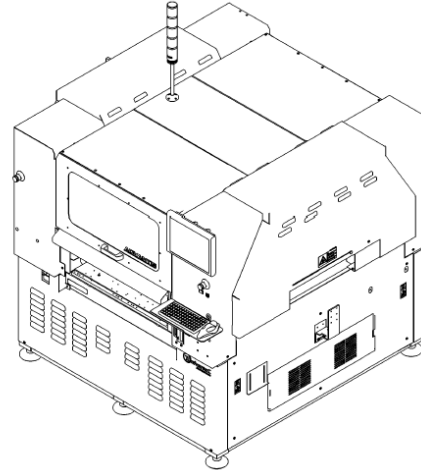

The AdVantis AC-30L is specifically designed to provide:

- Superior throughput
- High pick performance
- Fewer maintenance requirements
- Ease of use
- Broad component handling range, 0603mm (0201) to 30mm (1.18") square

Consistent with the original Platform concept, the AdVantis employs common mechanical, electrical, and software interfaces that allow Universal to develop options (heads, cameras, feeders, etc.) in response to changing production demands.

Many options developed for original GSM Platforms are still compatible with the AdVantis AC-30L. The AdVantis AC-30L uses the exact length and locations for air and power connections to simplify migration and reduce installation expenses.

The AdVantis AC-30L 4983A Platform shall comply with Appendix A of ESD-SP10.1-2000 for all markets.

## Construction

---

The AdVantis AC-30L is an automated electronic assembly machine built to assist in the manufacture of printed circuit boards (PCBs). Its primary function is to accurately place components on printed circuit boards.

The AdVantis AC-30L Platform is built on a solid welded steel plate frame and employs a single-gantry, dual drive positioning system. This allows a unique combination of high positional repeatability with high-speed component placement. A 30-spindle rotary head located on the X beam picks components from various fixed feeder locations. The components are vision inspected and then placed on a stationary PCB.

## Features

---

### Welded Base Frame

The welded steel base frame is designed to minimize tolerance accumulation from subassembly to subassembly. All major subassemblies are edge-justified or dowel-pin registered to precision datum surfaces or holes in the base frame. This ensures that the positional relationships are held mechanically, not through adjustment. This torsional stiffness contributes to maintaining reliability and reducing setup time associated with installing or relocating the machine on the factory floor.

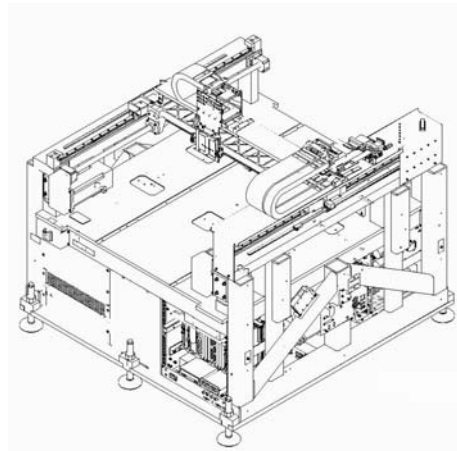

## Leadscrew Positioning System

The overhead, dual-gantry-positioning system utilizes Universal's patented linear motors, using VRM technology. VRM technology provides greater accuracy at faster acceleration and velocity than belt or lead screw driven positioning systems.

The X gantry is driven from both ends of the beam. This method eliminates "beam whip" (cantilevering) and positional errors experienced by single drive systems. In addition, settle times have been minimized, allowing the AdVantis AC-30L to reach higher placement speeds. 1-micron resolution linear scales are used to ensure positional repeatability and accuracy.

VRM technology is superior to other linear motor technologies because it maintains stable thermal characteristics during operating conditions. This guarantees that the AdVantis AC-30L linear motor will consistently run near ambient temperature, minimizing the effects of temperature change on accuracy and repeatability.

## Lightning Placement Head

The 30-spindle rotary placement head provides the foundation for high-speed small part placement.

The Lightning head features 30 intelligent spindle assemblies. Each quick-change intelligent spindle assembly provides a direct drive theta-axis as well as dedicated valves for vacuum generation and air kiss.

The head supports both a narrow field of view and a wide field of view camera, broadening the component range. All vision processing is performed "on the fly" to maximize throughput.

The head is equipped with a single Z-axis drive mechanism and strain gauge. The system learns and continuously updates X, Y, and Z-height pickup and placement locations. This assures accurate component pickup as well as true programmed placement forces.

The head utilizes an onboard reject bin for small components. This eliminates non-value-added time and any throughput derates associated with rejecting defective components.

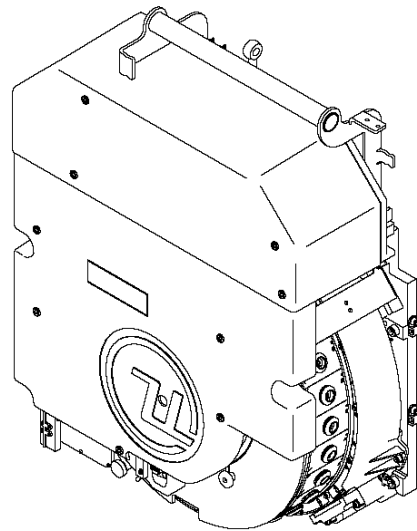

## Nozzles

Lightning nozzles are designed to provide a robust coupling between the spindle and nozzle assembly. Both stainless steel and compliant nozzles are available for use on the Lightning head. Stainless steel nozzles have a designed life expectancy of 8 million cycles, and compliant-tipped nozzles have a designed life expectancy of 3 million cycles. Of course nozzle life is dependant on many factors such as component types handled, nozzle cleanliness, excessive dry cycling, etc. Therefore, it is recommended that the customer budget for replacing all chip nozzles on an annual basis. Two Large Part Nozzle Kits are included with the purchase of each GC-60. Please refer to Nozzles in the Specifications section for more details.

## AdVantis AC-30L Camera Systems

Both cameras used on the AdVantis AC-30L Platform utilize CCD (charge-coupled device) technology. In addition, these camera systems support multiple angle illumination, which can utilize one or multiple angles to image any feature/component. All AdVantis AC-30L camera illumination systems can be easily calibrated to ensure consistency across cameras or machines over time.

## On-The-Head Cameras

Two on-the-head cameras mount directly to the Lightning head and maximize machine efficiency by imaging components while the head travels from the feeders directly to the PCB. The narrow field of view camera can image components from 0402mm (01005) to 8mm square. The wide field of view camera can image components up to 30mm square. The Lightning head is capable of imaging components up to 6mm tall with the use of short nozzles, and 30mm square. See Component Handling Capabilities in the Specifications / Performance section for limitations.

Both on-the-head cameras are equipped with front, side, and on-axis lighting, which can be activated individually or in concert to best illuminate a component's critical features.

See Camera Specifications in the Specifications / Performance section for more details.

## Fiducial Inspection Camera

Fiducials register the board in the machine and compensate for linear board distortions (stretch, shrink, and non-orthogonality). Local fiducials are used to measure local board distortions. A downward-looking pattern error correction (PEC) fiducial inspection camera is mounted under each beam. The field of view for these cameras is approximately 12mm square. Refer to Fiducial Locations in the Specifications / Performance section for details.

The PEC camera can process bad board sense features. It also utilizes three different illumination wavelengths (red, blue, and green) which can be programmed independently or in concert to create white light. Each wavelength expands the types of substrates or fiducials that can be imaged.

See Global and Local Fiducial Shapes and Dimensions section for more information.

## High Capacity Nozzle Changer

Two high capacity nozzle changers are installed on each AdVantis AC-30L. This provides a storage capability of 140 individual nozzles per head. The High Capacity Nozzle Changers are mounted between the rear feeder banks and rear board transfer rail, thereby maximizing online nozzle capacity without compromising board size or feeder capacity. Nozzle changing is only performed during job changeover. The nozzles on the Lightning head remain fixed during the production run. This nozzle changer is specifically designed for the Lightning head and is not compatible with FlexJet heads or any heads other than Lightning.

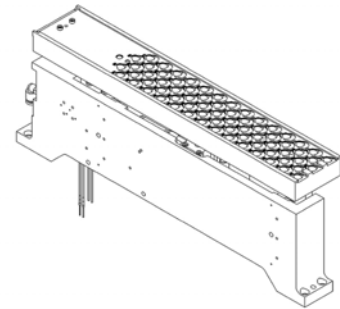

## Staged Board Handling

Staged Board Handling features an optional automatic width control based on programmed board parameters. While one board is being populated, the next board is buffered within the lane. Board transfer capabilities include left-to-right (default), pass-through, and right-to-left, as well as 3mm (default) and 5mm edge clearance. Mechanized board stops are standard and accommodate unique board shapes. Standard Staged Board Handling supports board sizes from 50mm long x 50mm wide x 0.5mm thick up to 508mm long x 457mm wide x 5mm thick.

Standard SMEMA interface is used to communicate to up-line and down-line modules.

See the Board Handling Specification section in the Specification/Performance section for more information.

## Board Support

This equipment minimizes the effects of board warp, sag, and/or flex by supporting the board during component placement. The board support uses a grid pattern containing removable pins. Removable board extensions are also available to increase the supported area for PCB's up to 635mm. In addition, the open architecture of the AdVantis AC-30L Platform supports integration of 3<sup>rd</sup> party board support systems. Refer to Board Support Specifications in the Specifications / Performance section for more details.

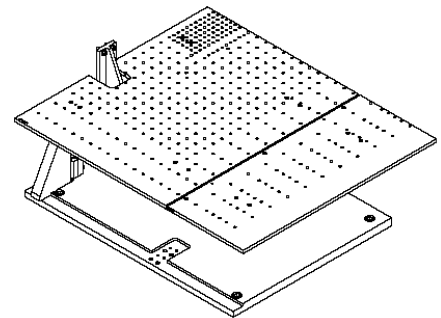



## PrecisionPro™ Feeder Interface

The AdVantis AC-30L Platform includes the PrecisionPro Feeder Interface for Continuous Splice PrecisionPro Tape feeders and feeder bank change support. The PrecisionPro Feeder interface incorporates the following features:

- 3-Point registration of 8mm and 12mm for improved pick performance when using PrecisionPro tape feeders
- 42V DC drive voltage for faster index rate of PrecisionPro tape feeders and increased throughput
- Self-ID control of PrecisionPro tape feeders with feeder serial number, cycle count tracking, and the ability to support multiple tape inputs in a single slot
- Support for new 18-slot Feeder Banks
- All PrecisionPro feeders up to 32mm are splice compatible, and include an option that detects when a reel has been removed, and requires barcode validation of the new reel to assure the correct reel is being spliced to the given feeder.

## 18 Slot Modular Feeder Banks

Four Feeder Banks may be installed on the base of the machine. Feeder banks come in two forms: fixed and removable banks. Any combination of fixed/removable banks are supported, however all four banks must be mounted for the machine to operate. These banks are compatible with GSM, Genesis and other models of AdVantis machines.

The mounting location allows two 18-slot feeder banks to be positioned side by side. The AC-30L configuration supports 17 accessible slots per feeder bank. This allows a total of 68 useable feeder slots. With the addition of a dual-track 8mm tape feeder, capacity grows to 136 inputs.

## AdVantis AC-30L Platform Machine Control System Architecture

The control system of the AC-30L includes the following:

- VME (Versa Module European) Bus
- Intel Pentium-based embedded CPU, with on board Ethernet controller, and 512Mb RAM
- IDE hard disk drive
- Motorola Power PC-based machine controller
- Intelligent DSP-based motion controllers
- CDR/W and floppy drives

## Microsoft Windows 2000 Operating System

The AdVantis AC-30L Platform uses Microsoft's Windows 2000 operating system. Windows 2000 provides:

- Expanded system security
- Easy data transfer and manipulation
- Multiple language support
- Better software development and test tools

## UPS+ (Universal Platform Software +)

Universal's UPS+ software runs on Microsoft Windows 2000 operating system. It provides state-of-the-art programming, operation, and diagnostic tools for use within the AdVantis AC-30L Platform. This software is the same software found on all AdVantis and Genesis platforms. Benefits of this commonality are:

- Common product editor across all machines
- Common component database across all machines
- Common user interface across all machines

### Basic Features of UPS+:

- Microsoft Windows 2000 operating system
- Graphic user interface with configurable icons and machine status messages
- Graphical pattern programming tools with spreadsheet-style data entry
- Networkable component and nozzle database
- User configurable optimization aid
- Comprehensive data import/export
- Powerful query tools
- Programmable feeder templates
- On-the-fly vision inspection, using ESI™ vision engine technology
- Enhanced product setup, simplifying component and board programming by teaching images
- Machine Status information display for quick ID of error and recovery



- Powerful diagnostic and manual axis control tools
- On-line Documentation
- AdVantis AC-30L can measure its own accuracy and repeatability performance and provide statistical information back through the user interface(MMI AT)
- Management Information includes detection and reporting of pick, vision inspection, feeder, nozzle, and head performance.
- Missing ball detection and pitch inspection for BGA and CCGA devices including all ball count
- Configuration template export facilitates off-line program generation, optimization, and simulation for multiple AdVantis AC-30L Platform configurations
- Software license manager. See additional information below in this section.

### Expanded System Security

- Administrator-level control to access levels(by individual or group)
- Access to individual UPS+ software files and folders, and operating system functions can be limited or denied based on user

- User-level event tracking
- User accounts can be imported and exported easily to other machines

**Built-in Links to Universal.com**

- Software updates and revision notes
- Documentation and procedure updates
- Service and support contact information
- Knowledge Base technical database
- Technical service bulletins



**On-line Documentation - VOYAGER Operation**

- Programming
- Maintenance support
- Feeder topics
- General information
- Related information links
- User created annotations and F1 "Quick Help" links

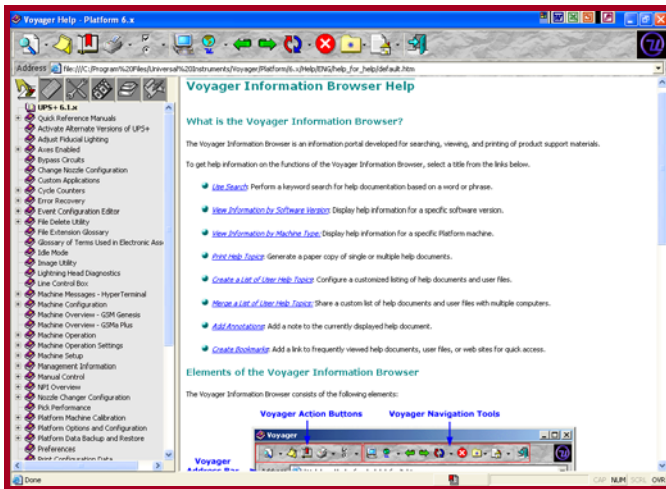

**Detailed Event Messages**

- Improved message descriptions
- Expanded access to further details and corrective action recommendations
- Search function within event messaging
- Color coded severity based on event significance.

### Detailed Error and Warning Messages

- Provides instructions and correct machine-stop conditions
- Warning events proactively alert user to potential machine-stop conditions
- 30 day warning period before expiration of the renewable software license manager key when applicable. Renewal instructions are provided
- Error-recovery screen automatically disappears when all errors and warnings have been addressed.

### Advanced Product Editor

- Allows overlapping circuits and unrestricted positioning of leads, components, fiducials and feeders for a wide range of applications
- Centroid-based CAD import utility(columnar or separator format)
- Programmable placement order within each task block
- Supports component ID's up to 32 characters
- Real time simulator
- Custom macro scripting
- Saves invalid products for future editing
- Optimizer includes quick or optional iterative long optimization
- CI2 Comprehensive Import incorporates an intuitive, flexible layout and supports partial import/export of individual components, feeders, or fiducials
- Product data status windows track 3 levels of error types, displays clear instructions that lead to valid product generation, and a "Go To" button to quickly view root-cause data
- Independent fiducial and nozzle databases.

### UPS+ Component Database

- Incorporates an intuitive layout that organizes data by tabs
- Unique programming values for multiple head and camera types that facilitates the existence of a factory-wide sharing of single component database
- Includes over 1,200 industry-standard default component definitions
- Spreadsheet –style data entry with tool tip information for each field to streamline data entry
- Supports offset pick and place centroid coordinates for a wider range of applications

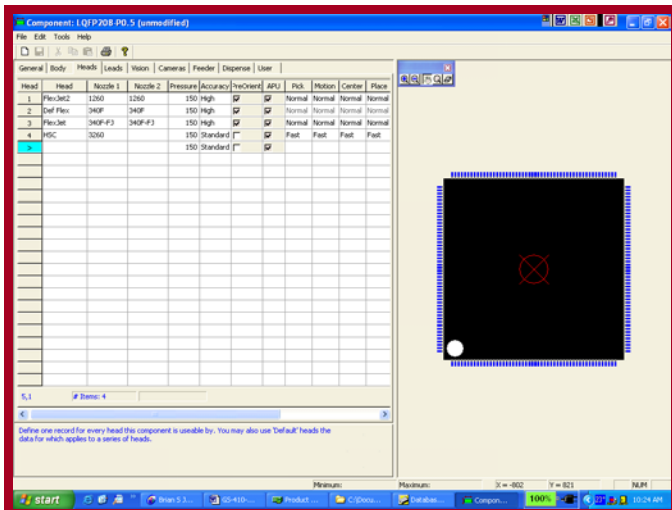

*Customizable User Interface Templates for the Following User Levels:*

Default templates:

- Operator
- Technician/maintenance
- Programmer
- Line Engineer
- Manager/Supervisor
- User
- Additional User Groups
- Operator(advanced)
- Guest
- Backup operator
- Power user
- Replicator

UPS+ allows for customer template and user group criteria, and simple import/export of user templates and accounts.

*Operator Interface and Production Setup Tools*

- Quick Image capture tool facilitates simple export of actual vision image bitmap file
- Nozzle setup routine guides operator through nozzle configuration setup during product changeover
- Runs in full screen mode (Operators can't access operating system)
- Includes quick access icon for nozzle and feeder performance data

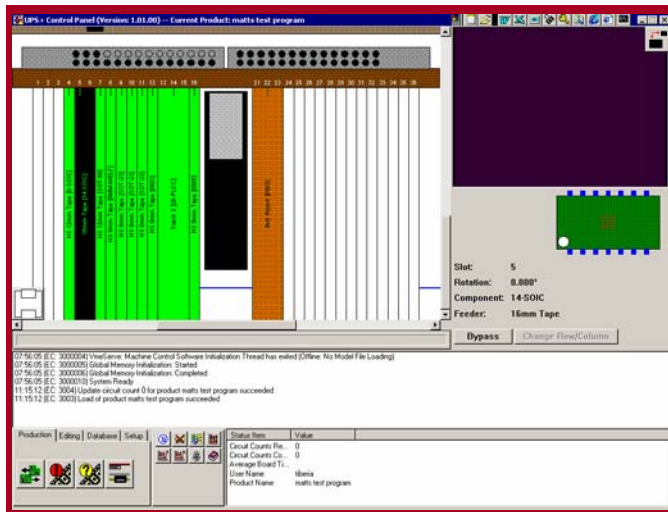

*Auto-Pick Update and Auto-Z Update*

- Auto-Pick Update automatically tunes feeder pick point based on vision results for optimal small-part pick performance. This feature is selectable by head and/or by Component ID.
- Auto-Z Update is a selectable feature that can be used at pick and/or place.
- Data is retained on product load and segment repairs
- Data is reset if a feeder is un-mounted, the feeder database is modified, or the machine is power cycled

When activated at pick, the machine learns the impact height when a part is picked from a feeder. This assures the component remains stable in its carrier during pick and minimizes nozzle wear.

When activated at place, the machine learns the impact height of each spindle during placement. This feature helps to eliminate such problems as improperly programmed component thickness and minimizes nozzle wear.

*Skip Component Quick Bypass*

- Selecting “Skip Component” within the feeder repair window quickly bypasses component
- Component remains bypassed until next product changeover
- Supports multiple component bypasses
- Configurable to standard or quick bypass skip component
- Allows the user to skip a component for just one board or for all boards

### True-to-scale Configuration Graphics

- Represent current real-time configuration of machine
- Add Hardware Wizard streamlines reconfiguration process
- Easy system-wide switch between English and Metric units of measure

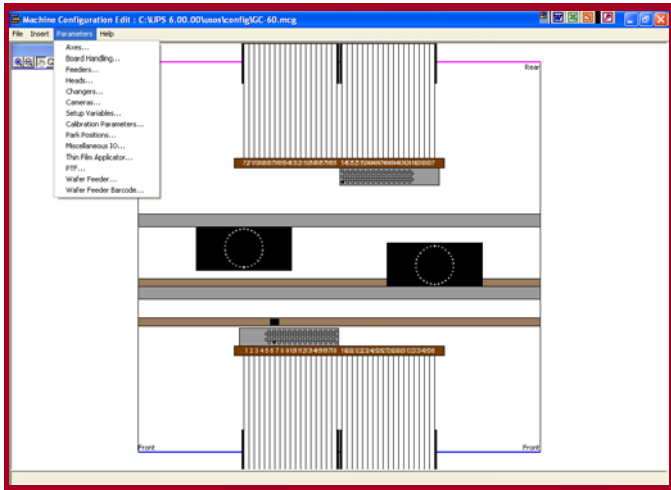

### Management Information System

- Powerful, flexible charting tools and graphics provide quick access to production detractors
- Configurable data query period by time interval, product, or operator
- Displays metrics as percentage, parts per million (PPM), or quantity
- Report generators
- Configurable screens
- Data sort function
- Custom query capability

### Diagnostic Tools

- Trend analysis graphically displays event history with powerful sorting, filtering, and statistical analysis tools for troubleshooting and maintenance
- Manual Axis Control feature incorporates user-friendly interface, vision image from PEC camera, and programmable intervals up to 10%
- Manual diagnostics feature provides advanced digital I/O diagnostics
- Pattern diagnostics feature facilitates motion control macros to cycle axes at programmable intervals and monitor servo motor performance
- One Button Debug Feature – This feature is used to collect machine data when an error occurs. This data can then be used by technical support to determine the cause of the error and correct it.

*New AC-30L Supported Features*

- Auto-spindle bypass
- Circuit level traceability
- Compliant tip nozzle support
- Board pass-through mode
- Optional New Product Introduction – Software tools that not only streamline and simplify the New Product Introduction process, but benefit everyday production by providing a quick and easy method to resolve process related issues. See New Product Introduction Section for more information.
- Dimensioning tolerance for chips on a component specific basis
- Auto Feeder Pocket Teach mode – When activated, automatically teaches the feeder pick location whenever a 0603mm (0201) , 1005mm (0402), or 1608mm (0603) feeder is installed on the machine. This provides a starting point for APU to fine tune pick performance while the machine is running
- Level 2 diagnostics for on-the-head-camera lighting
- Level 2 diagnostics for XY life testing
- New XP-style interface for NPI mode – Familiar interface to reduce learning time
- MMI AT (auto-trim) with live parts – More convenient method for quickly dialing in spindle offsets
- Circuit bypass
- Component pre-pick prior to board loading can be turned on or off
- 6mm tall component capability

*Recommended Off-line PC Configuration:*

- Microsoft Windows 2000 operating system
- 10 GB available hard disk space
- Pentium 4, 1.4 Giga-Hertz processor
- 1024 MB RAM

*Minimum Off-line PC Configuration:*

- Microsoft Windows 2000 operating system
- 4 GB available hard disk space
- Pentium 3, 400 Mega-Hertz processor
- 512 MB RAM

*Software License Manager Key:*

- Purchased UPS+ products are delivered with a “life of the product” software license key. This means that the operating system in a purchased UPS+ machine (including purchased options), and purchased Dimensions software applications, will continue running without interruption due to software license expirations.
- Products that are not purchased, such as those on loan for temporary evaluation or rental, may be delivered with shorter license keys that are set to expire after the temporary use has been completed. Further, some software options delivered with a purchased product may be separately keyed with a shorter validity period; this will be extended to a “life of the product” license upon purchase of the option.
- Software license keys may need to be revalidated due to other causes, such as certain hardware failures or forced date changes.

Please refer to your UPS+ Software Manual and/or UIC License Manager Manual for additional information.

## New Product Introduction Software (NPI)

---

Optional with every AdVantis AC-30L machine, the NPI software package provides the following benefits to not only New Product Introduction and First Article build, but to everyday production issues no matter what the manufacturing environment. Features included within this software are as follows:

### Feeder Inspection

- User can select all feeders or individual feeders to inspect.
- User can verify pick point, rotation, and pitch setting. Inaccurate data is updated and stored.
- An auto mode can be used to sequentially drive to each feeder selected without user intervention.
- Graphic overlays can be used if selected components have an orientation mark.
- Modifiable move increments ensure tight accuracy.
- User can index feeder from screen ensuring components are available for initial pick.

### Fiducial Inspection

- User can select all or individual Fiducials to inspect.
- Actual Fiducial find algorithms are executed ensuring that the Fiducials can be found. Corrections can be made to light levels and geometry.
- Fiducial locations can be updated. The first location updated will not affect CAD coordinates, but rather the reference point of the product so that the relationship to placements coordinates will not be lost.

### Pre-placement Inspection

- Users can select all placements or a subset of placements to inspect. A hot button can be used to select 1 of each component ID for inspection.
- Users can select Auto mode which automatically steps through placements, or steps through placements individually.
- Users can modify location and or rotation of components.
- Users can select to display a graphic of component with orientation mark.
- A drive-to-corner function is available if a component is larger than the field of view.

### Circuit / Offset Inspection

- Users may select Fiducials or placements to verify circuit/offset information
- Users can edit location and or rotation of circuits/offsets if necessary.

### Board Population

- Feeder, Fiducial, and placement errors should be corrected at this point.
- Corrections to component definitions may still be necessary (light level, geometry, etc.).
- Upon vision failures (in NPI full cycle mode) an error recovery screen pops up allowing the user to reject, skip, or edit the component.
- If editing, the component's description is displayed with the failed vision image.
- The user can reject, re-inspect, skip, or place the component with failed image.
- The user can edit the component definition and re-inspect the part until a successful image acquisition is received.
- The component stays on the nozzle until action is taken thus eliminating scrap.
- The zoom function can bring small components into an effective field of view for debug.
- A detailed log file comprehensively stores all modifications to components with pre and post change values.
- The log file can be overwritten, appended, or created per job depending upon the user's preference.
- Components can be placed without successful image acquisition if scrap is not possible. In this case, nozzle tip center will be used for placement centroid.

### Post-placement Inspection

- The user may select all or a subset of placements for post-placement inspection.
- The user may individually or automatically step through the selected placements.
- The user can verify rotations and or locations
- This is a semi-automatic optical inspection.



# Optional Equipment

## Input Power

The input power requirements on the 4983A AdVantis platforms is a nominal 200 – 240 VAC 3 Phase 50/60 Hertz

For customer supplied input power that falls outside of the range of the above power input options, there are external power conversion transformers available. Consult the AdVantis Product Team for more information.

## CE Compliance Input Filter

The AdVantis AC-30L Platform comes standard with all the hardware to conform to CE's physical safety standards. However, to be fully CE-code compliant, UIC offers an optional input filter that enables the machine to meet CE's Emission standards.

## Feeders

Feeder options include support for single and dual track continuous splice tape feeders, tape widths of 8mm – 44mm only. The AC-30L only supports High Performance Gold, PrecisionPro, and Electric (Black) tape feeders for component input. It does not support Pneumatic, Multi-Pitch, or any other types of feeders.

### Feeder Inputs

Feeder Type	Feeder Size	Number of Feeder Slots Consumed (Total Available = 68)
Tape Feeders	Dual Track 8mm	1 Slot – two 8mm inputs
	8mm and 12mm	1 Slot
	16mm, 24mm, 32mm	2 Slots
	44mm	3 Slots
Component Reject Station	N/A	3 Slots
Component Reject Bin	N/A	0 Slots

Refer to GS-412, Platform Feeders for more information.

## Feeder Bank Changing

For a given bank, while one removable bank option is being utilized in production on the machine, an offline removable bank can be setup/validated for the next job. The Feeder Bank Change option reduces changeover time by swapping up to 17 feeders at one time by one operator. Feeder bank change requires at least one feeder bank change cart, and one docking module for a given feeder bank. One additional feeder bank per docking module and at least one Feeder Setup Table are recommended for an effective Feeder Bank Change Option. Bank Change components and accessories are compatible with all AdVantis Platform machines. See 'Recommended Configuration' for an individual Bank or Machine.

### Feeder Bank Change Cart

The rolling Feeder Bank Change Cart option is used for Removable Feeder Bank installation, removal, or transport. Only one feeder bank on each side of the machine may be serviced at one time. Insertion or removal of a feeder bank requires the machine to be in a stopped condition.

A minimum of 1524mm (5') aisle space is required to properly maneuver the feeder bank change cart and service feeders. This equates to 4389mm (14.4') minimum machine spacing from front board handling fixed rail to fixed rail.

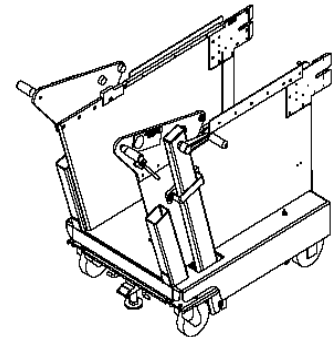

### Removable Feeder Bank Storage Table

The feeder bank storage table provides off-line storage for two removable feeder banks with or without feeders. The feeder storage table can be used for offline bank setup to minimize job change time.

### Feeder Setup Cart

This CE-compliant cart, used to load and index feeders, reduces production delays associated with feeder replenishment since feeders are easily prepared for use offline. This cart also increases Platform utilization by allowing for off-line feeder setup. A lower-cost tabletop version is also available.

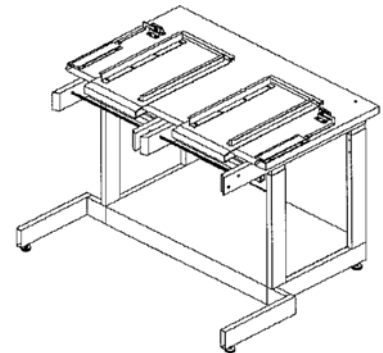

### Docking Module

A Docking Module is required to enable feeder bank change for any particular feeder bank location. Any combination of the four quadrants may be fitted with docking modules.

Docking module selection requires you to define which bank location you desire to mount this option.

## Recommended Configuration for an individual Bank or Machine

	Fully Bank Changeable Machine
Feeder Bank Change Cart	2
Removable Banks	8
Docking Modules <sup>1</sup>	4
Feeder Storage Tables	4

<sup>1</sup> Must identify which bank location to receive appropriate docking

It is important to note that all AdVantis removable banks are designed to conform to CE safety standards. AdVantis removable feeder banks are not GSM compatible and vice versa. Any attempt to use feeder banks not designed for the AdVantis machine violates CE safety compliance standards.

Feeder Bank Change can be configured on a per bank basis. For feeder bank locations that are not to be bank change capable, fixed feeder banks must be installed.

### Feeder Storage Cart

This cart reduces product changeover delays and improves work-place appearance by storing idle tape feeders in one convenient location. Each cart holds up to 132 8mm-tape feeders.

### Tape Scrap Bin

The rolling tape scrap bin provides a means of collecting tape scrap during production. Up to four scrap bins may be positioned at the AdVantis AC-30L Platform, one for each bank. Not compatible with dual-track 7-13" reel feeders.

### Low Profile Tape Scrap Bin

A low profile tape scrap bin is available to manage tape scrap for applications where the standard tape scrap bin or the scrap tape cutter is not compatible or practical. Up to four low profile scrap bins may be positioned at the AdVantis AC-30L Platform. This bin is compatible with all feeders and machine configurations.

### Component Reject Bin

Stores components that cannot be rejected using the On-The-Head reject bin. Components are stored in a bin and can be removed during routine machine maintenance. Two Reject Bins come standard with every GC-60 machine.

### Scrap Tape Cutter

The Scrap Tape Cutter is designed to cut off small pieces of reel tape and collect them in a collection bin for ease of disposal. This cutter can accommodate two banks of tape for disposal, maximum of two cutters per machine. The unit is mounted on wheels for easy mobility, and is supplied with a power cord to plug into the base machine. Refer to GS-412 (Platform Feeders) for more information.



Machine compatibility:

#### Fixed or Banks

The Scrap Tape cutter is fully compatible with all AdVantis fixed bank machines with the following exceptions:

Dual track feeders – When using a dual track 7 – 13" reel feeder, it is suggested that the feeder slot safety finger be removed for best performance. Any safety finger that has been removed must be replaced if no feeder occupies the feeder slot.

#### Additionally for Removable Banks

The Scrap Tape Cutter must be removed in order to perform a bank change.

#### With DPTF installed

The Scrap Tape Cutter cannot be used in conjunction with a DPTF

## Component Reject Station

Two modes of operation move rejected components away from the placement head and within reach of the operator:

- Programmable indexing cycles components until a sensor at the end of the belt's travel is interrupted, stopping the machine.
- The belt moves continuously, moving components off the end into a collection box

## Board Handling

---

### Long Board Kits

The AdVantis AC-30L Platform can be configured with a Long Board Kit. As a standard, the machine is capable of transferring boards up to 457mm (18") wide by 508mm (20") long. The long Board Kit expands the board size to 457mm (18") wide by 635mm (25") long

### Optional Board Support Systems

A Precision Lift board support system is available for applications that require custom tooling to provide precise support to the substrate being populated. This board support option is available as an RFQ only, please contact your local Universal sales engineer for further information.

## Calibration

---

### MCCM Calibration Fixtures

The AdVantis AC-30L Platform supports a portable MCCM (Mapping Calibration CPE MMI) Calibration system, utilizing fixtures that conveniently locate on the feeder banks.

MCCM also benefits customers in the following ways:

- All camera light levels can be calibrated to ensure illumination remains consistent across an entire factory over time
- Interruptions caused by user errors (i.e. fixture upside down), can be recovered during calibration thereby greatly reducing calibration time
- Any individual subsystem or complete system can be calibrated, thereby streamlining the calibration process
- Individual Intelligent Spindle Assemblies may be calibrated

### Auto-Trim/MMI Kit

Auto-Trim is a secondary calibration process that is required in order to dial-in spindle offsets. The Machine Measuring Itself (MMI) option allows the user to measure the placement accuracy and repeatability of the AdVantis machine using the machine positioning system and optics. This kit is part of complete calibration process to insure the highest level of placement accuracy.

Refer to GS-416, Calibration Kits, for more information

## Spare Parts and Tool Kits

---

### Spare Parts Kit

#### *Basic Spare Parts Kit*

The Basic Spare Parts kit includes items that are considered wearable items needing replacement on a regular basis, or items that may be susceptible to damage. The AC-30L Basic Spare parts kit includes the following:

- Leveler assembly
- Timing belts
- Transfer belt
- Fuses
- Hard-drive
- Coupler

#### *Chemical and Lubrication*

The Chemical and lubrication kit includes the grease and oils required to properly maintain the AC-30L. The lubricants included are as follows:

- Isoflex grease
- Kluber GLY2100 oil
- Molykote G4500 Grease
- Synthetic Anderol grease

Failure to use Universal specified maintenance schedules and lubricants may void factory warranty.

#### *Lightning Head*

This spare parts kit includes items that are either considered wearable and/or items that are easily replaced in the event of a failure. Items in this kit include the following:

- Slip ring assembly
- Circuit boards
- Read head assembly
- Z axis motor
- Strainage assembly

#### *Spindle Kit*

This spindle kit includes air filters and five spindle assemblies. At least one kit per machine is recommended.

#### *Pneumatic Filter Kit*

This kit contains a replacement filter and separator for the main air supply. At least one kit per site is recommended. The filter can and should be cleaned every six weeks according to the preventative maintenance schedule, and must be replaced every two years.

### Tool Kits

#### *AdVantis Tool Kit*

The AdVantis Tool kit includes the tools required to perform the proper maintenance on the Platform. This kit includes the following item:

- Machine zero fiducial fixture for establishing machines zero when necessary
- Grease gun
- Stator lubrication tool kit – contains applicator and oil
- Pipe coupling – customer grease gun attachment for accessing grease fittings
- 12" needle nozzle – customer grease gun attachment for accessing grease fittings
- Curved outlet pipe – customer grease gun attachment for accessing grease fittings
- Cleaning cloth

A minimum of one kit per site is recommended. Additional kits may be added to help expedite routine maintenance.

### *Lightning Head Tool Kit*

This tool kit contains all the necessary tools required for maintaining the Lightning placement head. This kit includes the following:

- Vacuum test fixture
- Spacers for read and scanning head setup
- Hex drivers
- Retaining ring pliers
- Custom grease tips

A minimum of one kit per site is recommended. Additional kits may be added to help expedite routine maintenance.

## Installation Kits

### *Platform Installation Kit*

This kit includes all the basic tools required to install and or move an AdVantis Platform machine. One kit per site is recommended. This kit includes the following:

- Ratchet
- Sockets
- Precision Level
- Spanner wrench
- Combination wrench

### *GSMA / AdVantis Install Tool Kit*

This kit is a complete collection of tooling used to install and prepare a machine for production. This kit includes most items included in the Platform Installation kit plus the following:

- Additional sockets
- Torque wrenches
- Feeler gauges
- Additional ratchets
- Grease gun
- Dial indicator
- Combination and open end wrenches
- Ratchet and socket adapters
- Hex bits
- Y-axis tach fixture

### *GSMA Add-on Install Kit*

This kit adds installation tools to older kits to so that the older kit contains the same set of tools as the above Platform Installation Kit. The kit also duplicates a ratchet, socket, and combination wrench to replace potentially worn out tooling.

## Software

---

### Machine Level Software Options

#### *GEM*

Generic Equipment Model (GEM) software provides a set of communication, data collection, command and control tools for the AdVantis AC-30L Platform. This software driver based on the Semiconductor Equipment and Materials International standard (SEMI E30-93) opens the system architecture for integration into factory data collection and automation systems.

#### *Platform Traceability*

Traceability at the component and board level gives you a closed-loop feedback system that can both confirm quality and zero in on potential problems – quickly, easily, accurately, and automatically.

Refer to GS-414, Dimensions General Specifications, for more information

#### *Bar Code Product Changeover*

The AdVantis AC-30L Platform is capable of handling bar code changeovers if it is equipped with the Bar Code Changeover option. This option allows for seamless product changeovers without requiring the user to manually load product data or press the start button. The changeover is accomplished when a bar code string is received, then a lookup is performed in a cross-reference lookup table to verify what product should be executed for a given bar code.

This option is completely local to the AdVantis AC-30L Platform. No external host machine is required. It is a separate purchased option to the UPS+ software.

Refer to Appendix B for information on bar code types accepted.

Refer to GS-414, Dimensions General Specifications, for more information.

#### *Platform Setup Validation (PSV) Option*

The AdVantis AC-30L platform supports Platform Setup Validation (PSV), which prevents operator-related errors during feeder setup or reloading by verifying the correct components are loaded into the correct feeder slots. PSV minimizes product costs by reducing rework, thereby improving product yield while providing a validation log, which tracks each feeder dismount, scan, and mount routines. Minimal operator training is required due to the simple closed-loop operation and common look of the graphical user validation.

Incorporating PSV provides numerous benefits:

**Prevents operator related loading errors:** The closed-loop feedback system ensures the correct feeders and components are loaded into the appropriate feeder slot whenever a tape feeder is mounted or spliced on the AdVantis platform

**Eliminates costly rework:** Since PSV cannot enable a mismatched component and feeder slot; the wrong components are simply not picked, thus preventing any associated rework.

**Improves product yield:** PSV ensures correct component usage. This means you won't be forced to rework boards because the wrong part was placed. Hence, your first product pass yield may increase.

**Increases operational efficiency:** When integrated with Dimensions and GEM software, component consumption can be monitored / integrated into a customer's MRP system to assure parts are replenished without production interruption.

Refer to GS-414, Dimension General Specification for more information.

### Line Level Software Options:

Please refer to GS-414, Dimensions General Specification, for more information on line level software.

# Specifications

## Installation Specifications

### Installation Considerations

#### Machine Dimensions: AdVantis AC-30L

	Length <sup>1</sup>	Depth <sup>2</sup>	Height <sup>3</sup>	Weight
Base Machine	1676mm (66")	1689mm (66.5")	2212mm (87")	2600kg (5700lbs)
Domestic Shipping	1905mm (75")	2591mm (102")	1854mm (73")	3089kg (6809lbs)
Air Freight	1930mm (76")	2616mm (103")	1854mm (73")	3302kg (7279lbs)
Sea Freight	Same as Air	Same as Air	Same as Air	3373kg (7435lbs)

Notes:

- 1 Length is in the direction of board flow
- 2 Depth does not include user interface screen
- 3 Machine light tower included in height

#### AdVantis AC-30L Platform Installation Hardware:

10k lb. Lift Truck with 10ft length forks

#### Floor Loading Requirements

(See following diagrams)

Units	AdVantis AC-30L	Comments
Static Floor Loading (N/m <sup>2</sup> )	9600	w/o Feeders
Static Floor Loading (lb/ft <sup>2</sup> )	200	w/o Feeders
Static Floor Loading (N/m <sup>2</sup> )	11000	w/Feeders
Static Floor Loading (lb/ft <sup>2</sup> )	230	w/Feeders
Dynamic Load/Area (N/m <sup>2</sup> )	1400	
Dynamic Load/Area (lb/ft <sup>2</sup> )	30	
Total Floor Loading (Static + Dynamic) (N/m <sup>2</sup> )	12400	w/o Feeders
Total Floor Loading (Static + Dynamic) (lb/ft <sup>2</sup> )	260	w/o Feeders

Notes:

- All loads are assuming machine is properly leveled and the load is evenly distributed.
- Loads are based on 6" (150mm) reinforced concrete on compacted soil sub-base.
- Loads are calculated as average over the area occupied by the machine leveling system.
- Loads per unit area are concentrated about leveling legs.
- Weights with Feeders are based on 72 Dual Track 8mm Feeders with 2 - 7" Reels.
- All loads are vertical.
- Dynamic loads will be applied upward and downward.
- It is the customer's responsibility to determine appropriate structural requirements to support the machine.



The following diagrams illustrate the effects of Static and Dynamic floor loading. The Static diagram illustrates the footprint of the machine and the locations of the footpads to determine the surface area affected by the Static Floor Loading. The Dynamic diagram illustrates the forces applied to the floor as the positioning system moves.

This information is supplied for illustrative purposes only. It is recommended that a Structural Engineer be consulted to determine the proper floor loading requirements.

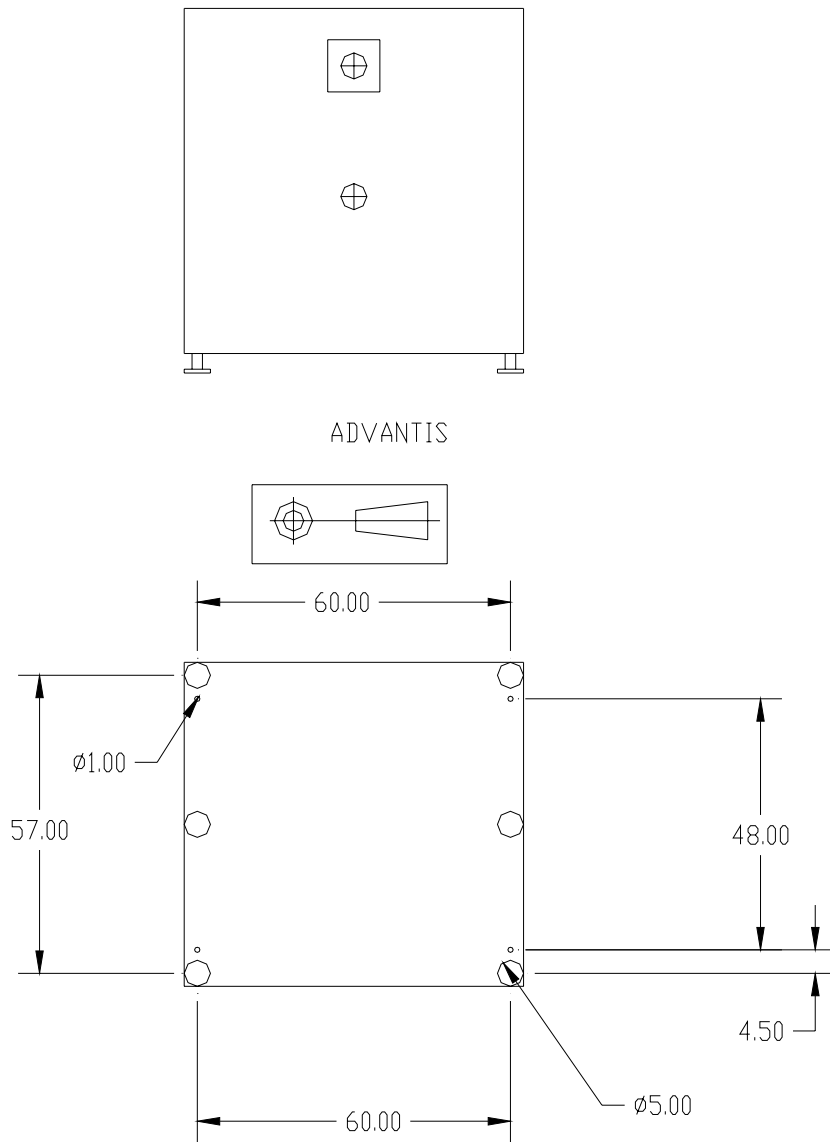

*Service Requirements*

<b>Electrical</b>	200-240VAC, nominal
Frequency	50 or 60 Hz (49-51 or 59-61 Hz)
Phases	3
Numbers of Wires	4(3 Phases and Ground)
Service Configuration <sup>1,2</sup>	Must be grounded Delta, or Wye
Branch Circuit Size	30 Amps
Distortion	<10% total Harmonic distortion
Average Power	5000 watts
Electrical Connection	76.2mm (3") front left corner 686mm (27") from floor

1 A customer-supplied transformer **cannot be a** "SPLIT-PHASE AUTOTRANSFORMER." Split-phase transformers are typically two small autotransformers that get wired in series with the machine. The machine warranty will be voided if a customer attempts to operate AdVantis in this configuration.

2 Do not hipot test the AdVantis machine due to risk of damage to the machine's electronics. AdVantis utilizes a transformer-less AC Input System. Subjecting the machine to hipot testing will void the machine's warranty.

*Pneumatics (clean air)*

Air Flow <sup>1</sup>	3.0 CFM @ 90psi (84.92 liters/min @ 6.2 bars)
Air Consumption <sup>2</sup>	10 SCFM (283.2 liters/min)
Pneumatic Connection	12.7mm(1/2") or larger to machine 254mm (10") from left front corner, 152mm(6") from floor. Internal thread connection is 1/2 NPT and provided with the machine. Equipment is adequately protected against ingress of solid and liquid contaminants.

Notes:

1 Air Flow values are used to represent momentary peaks of demand for the machine to size input airlines. As with air consumption, it accounts for heads.

2 Air consumption is an average for air used by the base machine during a normal machine cycle and is measured in standard cubic feet per minute. It accounts for heads.

*Clean Air is defined as:*

1	Dew Point	Must be 20 degrees F (11 degrees C) below ambient temperature
2	Oil	.08 ppm at 82 degrees F (28 degrees C)
3	Input Air	Filtered to 5 microns particle size

*Environmental Requirements*

	Minimum	Maximum
Operating Temperature	4.4 Degrees C 40 Degrees F	35 Degrees C 95 Degrees F
Operating Temperature Change Tolerance		6 Degrees C/Hr 10.8 Degrees F/Hr
Storage Temperature	-20 Degrees C -4 Degrees F	65 Degrees C 149 Degrees F
Operating Humidity	10% non-condensing	90% non-condensing
Operating Altitude		2500 Meters 8202 Feet
Noise Level <sup>1</sup>		72dbA

1 In accordance with National Machine Toolbuilders Assoc. Noise Measurement Technique Standard – June 1986

AdVantis AC-30L Platform Footprint:

Front View

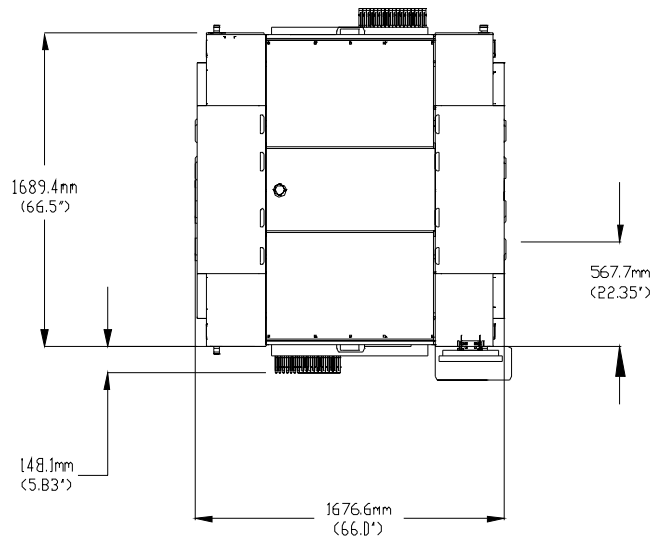
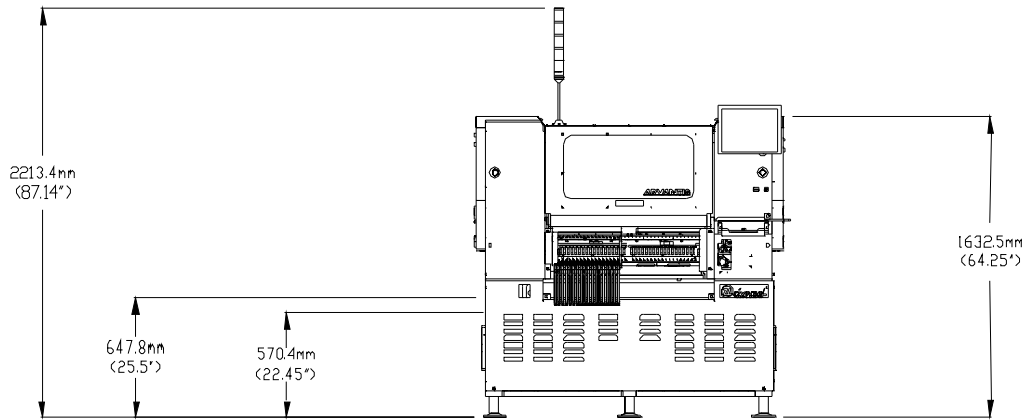

Top View

*Aisle Considerations for Use of Feeder Carts:*

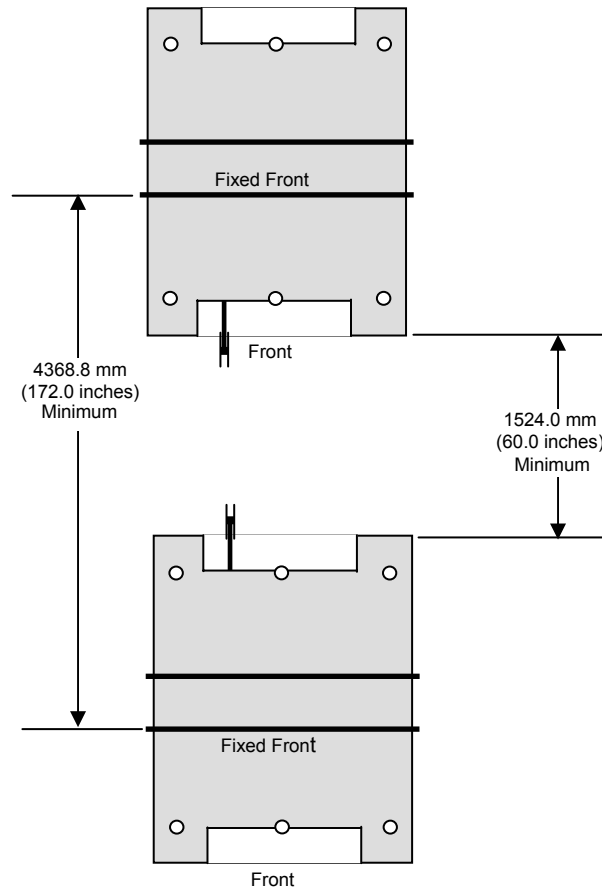

## AdVantis Positioning System Specifications

---

X Axis Travel	703.56mm (27.7")
Y Axis Travel	869.95mm (34.25")
Resolution	.0010mm (.00004")

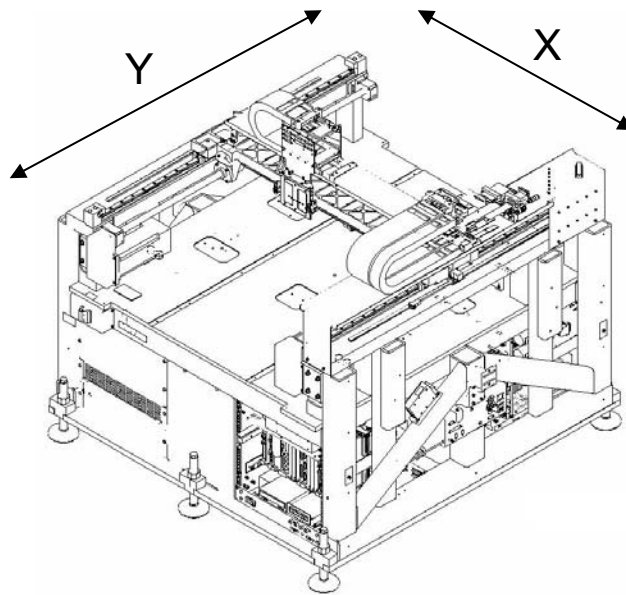

## Placement Head

### Lightning Head Specifications

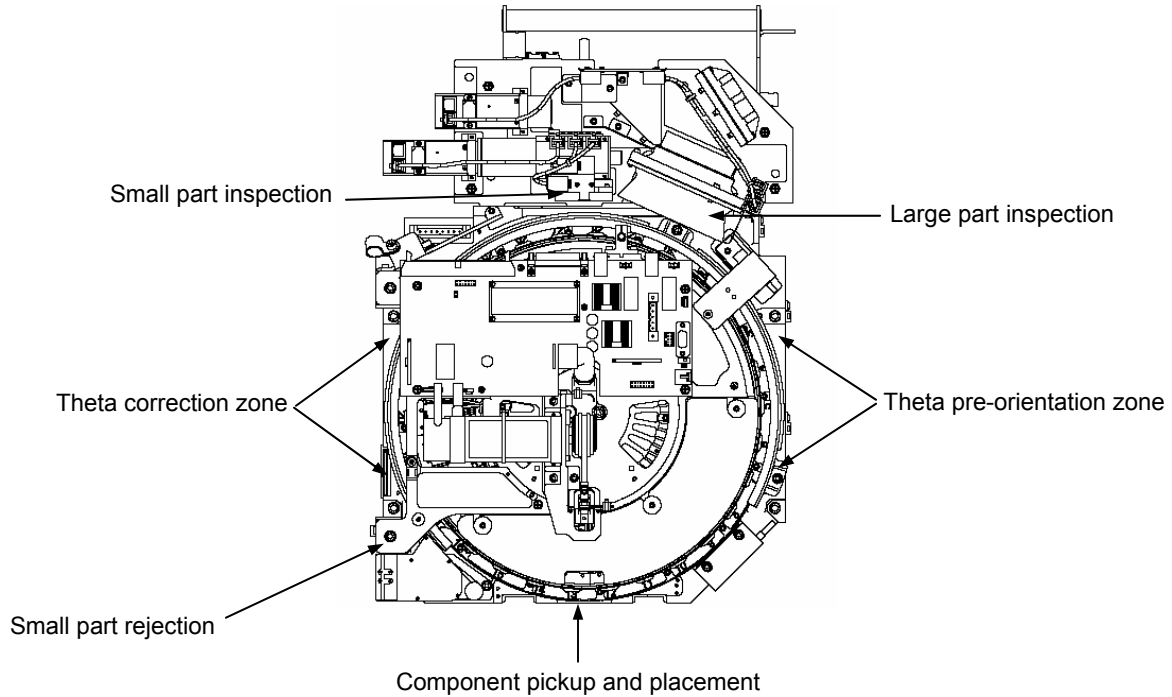

### Component Handling

Component Handling Capabilities	Lightning	
	Minimum	Maximum
Component Width	0.3mm (0.012")	30mm <sup>3</sup> (1.181")
Component Length	0.6mm (0.024")	30mm <sup>3</sup> (1.181")
Component Height	0.15mm (0.006")	6mm (0.24") <sup>2</sup>
Component Weight		4 gr <sup>1</sup>
Placement Force (grams)		200 ± 20%
MELF Diameter		3.5mm (0.14")
Lead Pitch (wide camera)	0.3mm (0.012")	
Lead Pitch (narrow camera)	0.1mm (0.004")	
Minimum Lead Width (30 mm Square Component Size)	0.46mm (0.018")	
Minimum Lead Width (20 mm Square Component Size)	0.36mm (0.014")	
Bump Diameter (narrow camera)	0.102mm (0.004")	

Notes

1 Additional weight possible, consult product team

2 4 – 6 mm part height require correct nozzles

3 For components greater than 20mm square, an RFQ is required

On-The-Head-Camera Specifications

<b>Maximum Component Size</b>	Camera			
	0.8 mil/pixel		2.87mil/pixel	
	mm	Inches	mm	inches
Maximum Component (square)	8.000	0.315	30.000	1.182
Maximum Component Height	6.000 <sup>1</sup>	0.236	6.000 <sup>1</sup>	0.236
<b>Leadless Components</b>				
Minimum Length	0.244	0.010	0.875	0.034
Minimum Width	0.122	0.005	0.437	0.017
<b>Leaded Components</b>				
Minimum Pitch	0.081	0.003	0.292	0.011
Minimum Length/Width - Centering	0.041	0.002	0.146	0.006
Minimum Length/Width - Inspection	0.051	0.002	0.182	0.007
<b>Multi-Pattern Components</b>				
Minimum Centering	0.122	0.005	0.437	0.017
Minimum Inspection	0.132	0.005	0.474	0.019
<b>BGA &amp; C4</b>				
Minimum Pitch	0.203	0.008	0.729	0.029
Minimum Ball Dia	0.102	0.004	0.364	0.014
Minimum Ball Spacing	0.081	0.003	0.292	0.011
1 with short nozzles				

## Nozzles

### Lightning Nozzles

In addition to the large part nozzle kits shipped with each machine, the customer must also select either a small part nozzle kits or elect to order the required nozzles independently. All nozzles and nozzle kits are outlined below.

#### Available Nozzles

Nozzle	Description	OD/ID (mm)	Sample Component Range	Designed Life Expectancy (cycles)
<b>Compliant Tip Nozzles</b>				
3220	Nozzle Tip 125	3.23 / 2.16	1812, PLCC18, SOIC8, SOIC14	3 million
3240	Nozzle Tip 234	5.94 / 2.79	SOIC18, SOJ42, ALCAP10x10	3 million
3260	Nozzle Tip 340	8.64 / 5.08	PLCC100, PLCC32, PLCC84, QFP100, QFP160, SOIC10	3 million
3520	Nozzle Tip 402 Compliant Blade	N/A	0402C, 0402R	3 million
3530	Nozzle Tip Compliant 603	0.904/0.701	0603C, 0603R	3 million
3540	Nozzle Tip Compliant 805	1.3 / 0.899	0805C, 0805R	3 million
3550	Nozzle Tip Compliant 1.8mm	1.8 / 1.1	1206C, 1206R, 1210C, 1210R	3 million
<b>Melf Nozzles</b>				
3320	Nozzle Tip 042MF	1.32/1.02	MELF - 2.0x1.3	8 million
3340	Nozzle Tip 083MF	2.11/1.60	MELF - 3.4x1.4 to MELF - 9.3x2.6	8 million
<b>Stainless Steel Conical Nozzles</b>				
3420**	Nozzle Tip 402	0.599 / 0.399	0402C, 0402R	8 million
3430	Nozzle Tip 603	.904/.701	0603C, 0603R	8 million
3440	Nozzle Tip 805	1.3/0.9	0805C, 0805R	8 million
3450	Nozzle Tip 1.8mm	1.8/1.1	1206C, 1206R, 1210C, 1210R	8 million
<b>Bladed Chip Nozzles</b>				
3020*	Nozzle Ceramic Tip 0201	N/A	0201C, 0201R	TBD

\* Preliminary Placement Density is .008" (.2mm)

\*\* Placement Density is .012" (.3mm)

#### Standard Large Part Nozzle Kit – Supplied with each Lightning Head

Nozzle Code	Quantity in Kit
3220	4
3240	4
3260	4
3320	4
3340	4

#### Recommended Small Part Nozzle Kit

Nozzle Code	Quantity in Kit
3420	30
3530	30
3540	30
3550	30



## Fiducial Specifications

### Global and Local Fiducial Shapes and Dimensions

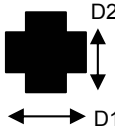
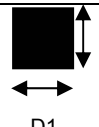
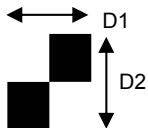
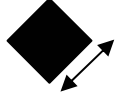
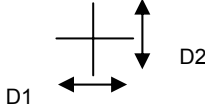
Shape	D1	D2
 Disc	Min=0.40 mm (0.016") Max=6.10 mm (0.250")	—
 Swiss Cross	Min=1.02 mm (0.040") Max=6.35 mm (0.250")	Min=0.508mm(0.020") Max=5.84 mm(0.230")
 Rectangle (Square)	Min=0.40 mm (0.016") Max=6.35 mm (0.250")	Min=0.40 mm (0.016") Max=6.35 mm (0.250")
 Double Box Left or Right	Min=1.0 mm (0.040") Max=6.35 mm (0.250")	Min=1.02 mm (0.040") Max=6.35 mm (0.250")
 Diamond	Min=1.0 mm (0.040") Max=6.35 mm (0.250")	—
 Plus	Min=0.762 mm (0.030") Max=N/A	Min=0.762 mm (0.030") Max=N/A

**Recommended Fiducial and Bad Mark Sense**

Universal recommends that a minimum of three global fiducials be used for boards assembled on the AdVantis Platform—two to six fiducials depending on the process. Although the AdVantis Platform handles a range of fiducial types, the most reliable fiducial recommendations follow:

<b>Shape</b>	Disc (solid, filled circle)
<b>Size</b>	Minimum -- 0.8 mm (0.032") Maximum -- 3.00 mm (0.118")
<b>Tolerance</b>	0.025 mm (0.001")
<b>Clearance</b>	The fiducial clearance area must be at least two times the diameter of the fiducial.
<b>Material</b>	Bare copper or copper covered with either clear anti-oxidation coating, nickel plating, tin plating, or hot air leveled solder coating.
<b>Flatness</b>	The fiducial surface should be flat within 0.015 mm (0.0006")
<b>Mask</b>	Solder resist coatings should not cover a Fiducial mark or its clearance area.
<b>Max # of Fids</b>	500
<b>Max # of Bad Sense Marks</b>	254

**Board Handling Specifications**

**Board Specifications – Standard Board Handling**

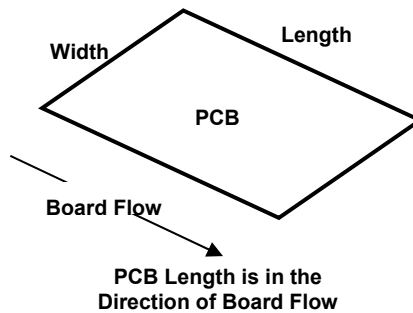

	Minimum	Maximum
Length	50.8mm (2")	508mm (20") <sup>1</sup>
Width	50.8mm (2") <sup>2</sup>	457mm (18")
Thickness	.508mm (.02")	5.08mm (0.2")
Weight		2.72kg (6lbs) <sup>3</sup>
Allowable Warp	For Board Transfer	5.537mm (.218") minus board thickness
	For Placement	.75% of board length(per IPC-2221), not to exceed 3.175mm (.125") total

<sup>1</sup> Standard tooling accommodates board length up to 508mm. See large board kits section for alternatives.

<sup>2</sup> The component reject bin must be relocated and one mechanical stop removed to accommodate board width between 50.8mm (2") and 88.9mm (3.5"). Software reconfiguration is required.

<sup>3</sup> Represents the sum of all board weights within the AdVantis AC-30L Platform board handling system and components placed.

Board Clearance

Topside Clearance Before Placement	Tallest part on board + thickest part being placed by Lightning must be less than 11mm (Assumes no board warpage in the clamped position)
Bottom Side Clearance	See Illustration

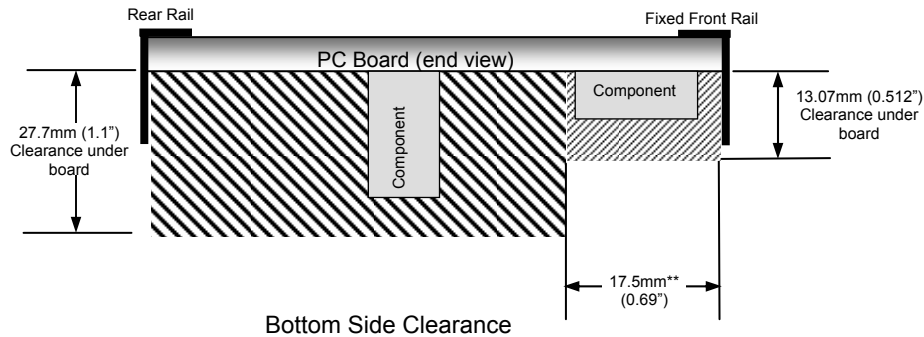

\*\*For 5mm edge clearance, add 2mm to 17.5mm = 19.5mm

Board Handling Dimensions

	Minimum	Maximum
Transfer Height	899mm(35.4")	965.2mm(38")
Transfer Time		2.5 sec
Edge Clearance	Standard	3mm(0.19"), +/- .4mm(.016")
	Optional	5mm(0.2"), +/- .4mm(.016")

Board Support Specifications

Board Support	Max Board Width Supported	Max Board Length Supported
Standard	457mm (18")	508mm (20")
Long Board	457mm (18")	635mm (25")*

\*Requires the use of the board support extensions provided with the standard board handling on new machine orders only

Long Board Kit

The Long Board kit modifies the standard board handling to accommodate boards sizes up to 635mm (25") long by 457mm (18") wide.

	Minimum	Maximum
Length	50.8mm (2")	635mm (25")
Width	50.8mm (2") <sup>1</sup>	457mm (18")
Thickness	.508mm (.02")	5.08mm (0.2")
Weight		4.99kg (11lbs) <sup>2,3</sup>
Allowable Warp	For Board Transfer	5.537mm (.218") minus board thickness
	For Placement	.75% of board length(per IPC-2221), not to exceed 3.175mm (.125") total

1 The component reject bin must be relocated and one mechanical stop removed to accommodate board width between 50.8mm (2") and 88.9mm (3.5"). Software reconfiguration is required.

2 Represents the sum of all board weights within the AdVantis AC-30L Platform board handling system and components placed.

3 5mm edge clearance required for boards over 3.18kg (7 lbs).

## Performance Capability

### Performance

<b>Final Placement Performance</b>	50 DPM
<b>Intrinsic Availability</b>	98%
<b>Maintenance Interval</b>	5.7 Hours every 6 weeks

### Placement Capability – Universal Reference Method with Glass Slugs on Glass Plates

Camera Type	Part Type	X/Y Spec Limits (um)	Theta Spec Limits (deg)	Min Cpk
OTHC	Leadless*	65	N/A	1.33
	Leaded*	65	1.0	1.33

\* Board-to-board

### Machine Speed

CPH	Part Type	Comments
33,600	1005(0402)	Maximum CPH*
21,000	1608 (0603)	4 board IPC

\*Note: Based on chip – 0402 (1005) chip capacitor, picking 60 components on UIC speed pattern

# Appendix A

## Model Specifications Summary

Machine Configuration	AdVantis AC-30L
<b>Machine Architecture</b>	
Machine Type	Gantry
Number of Gantries	1
Drive System	Dual Drive Leadscrew
X,Y Motor Type	Servo
Operating system	Win 2000
<b>Machine Capabilities</b>	
Machine Dimensions	
Length x Depth (meters)	1.67 x 2.25
<b>Board Handling</b>	
Max Board Size	
Standard(L x W) (mm)	508 x 457
Load Time(s) - Standard	3
Optional (L x W) (mm)	635 x 457
Load Time(s) - Optional	6
Dual Lane Option	No
	12.7 pass-through / 11 placement
Topside Clearance (mm)	
Bottom side Clearance (mm)	27.7
<b>Feeders</b>	
8mm Input	136
12mm Input	68
16mm Input	34
Tube Input	No
Bulk Input	No
Bank Change	Yes
Splicing	Yes
<b>Component Capabilities</b>	
Min Component	0603mm (0201")
Max Component (square) - standard	20mm (0.79")
Max Component (square)	30mm (1.18")
Max Component Height	6mm (0.24")
Min Component Pitch	0.1mm(0.004")
Min Ball Dia.	109um
Placement Force(grams)	200 ± 20%
Special Vac Nozzle (Oddform)	No
Gripper Nozzle (Oddform)	No

Machine Configuration (continued)	AdVantis AC-30L (cont)
<b>Performance</b>	
Max CPH	33,600
CPH/m <sup>2</sup>	15,170
1608 CPH – Single Lane board Handling	21,000
100QFP CPH	-
Practical Chip TACT	0.1125
Practical SOIC TACT	0.18
Practical Odd-form TACT	N/A
<b>Accuracy</b>	
1608 Accuracy	65um @ 1.33 CpK
100QFP Accuracy	65um @ 1.33 CpK
<b>Supported Hardware</b>	
Head Type	Lightning Head 30-Spindle
Upward Looking Camera	N/A
PTF	No
SMTF	No
DPTF	No
Wafer Handler	No
PrecisionPro Feeder Intfc/Bank Change	Yes
Nozzle Changer Inventory	140
<b>Production Characteristics</b>	
Auto Nozzle Change during production	During Changeover
Linear Sensor Equipped	No
Repair Mode	End of pattern
Vision lighting modes	Front
Qty of Feeder duplicates for High-Running Component(Min.)	1
Closed-Loop Splice Validation	Yes

# Appendix B

## Bar Code Types

The scanner is a high-density .127mm (.005") line width, capable of reading the following bar code types:

Code 39; UPS; Codabar; Code 128; Interleaved 2 of 5

Narrow Bar Width	Read Range	Maximum Scan Width
<b>High Density, Right Angle Down</b>		
0.127 mm (0.0050")	50.8 mm to 78.7 mm (2" to 3.1")	53.3 mm (2.1")
0.191 mm (0.0075")	50.8 mm to 102 mm (2" to 4")	91.4 mm (3.6")
<b>Low Density</b>		
0.191 mm (0.0075")	63.5 mm to 140 mm (2.5" to 5.5")	102 mm (4")
0.254 mm (0.0100")	50.8 mm to 165 mm (2" to 6.5")	127 mm (5")
0.381 mm (0.0150")	50.8 mm to 190 mm (2" to 7.5")	152 mm (6")
0.508 mm (0.0200")	50.8 mm to 254 mm (2" to 10")	178 mm (7")
0.762 mm (0.0300")	50.8 mm to 254 mm (2" to 10")	178 mm (7")
1.02 mm (0.0400")	50.8 mm to 254 mm (2" to 10")	178 mm (7")
<b>Right Angle Down</b>		
0.191 mm (0.0075")	31.8 mm to 102 mm (1.25" to 4")	102 mm (4")
0.254 mm (0.0100")	25.4 mm to 127 mm (1" to 5")	127 mm (5")
0.381 mm (0.0150")	25.4 mm to 152 mm (1" to 6")	152 mm (6")
0.508 mm (0.0200")	25.4 mm to 216 mm (1" to 8.5")	178 mm (7")
0.762 mm (0.0300")	25.4 mm to 216 mm (1" to 8.5")	178 mm (7")
1.02 mm (0.0400")	25.4 mm to 216 mm (1" to 8.5")	178 mm (7")

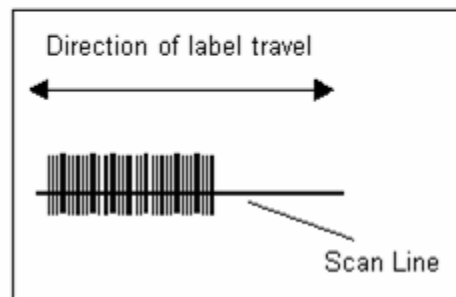
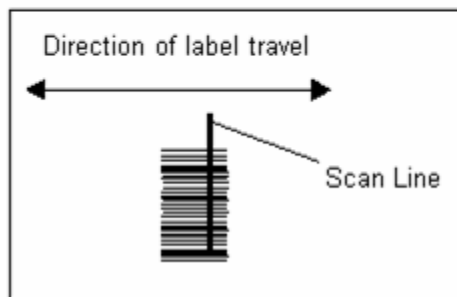

# Appendix C

## Acceptance Criteria

SRVC001.1.Rev. H

### Core Machine Acceptance Testing

This document outlines the standard and optional protocols for Factory QAC Testing at Universal and Final Acceptance Testing (commissioning) at the customer's facility. Standard protocols are included at no additional cost to the customer. Optional protocols proceed through Universal's Request For Quote (RFQ) process to determine the additional cost and schedule impacts.

- Systems: **see separate Systems Acceptance Testing section below.**
- OFA Division **assembly products are processed through RFQ and are not covered by these processes.**

**Standard Factory QAC:** Factory Quality Assurance Checklist (QAC) testing and inspection is performed by Universal personnel in accordance with detailed processes to assure that the machine(s)/systems we deliver meet Universal's exacting quality standards. Throughput, accuracy, yield, and intrinsic availability are tested in accordance to established Universal and Industry standards. Results are documented and verified against published specifications. If any process is found to be outside acceptable performance parameters, testing is halted, the root cause of the failure is determined and corrected, and testing is restarted. Machines that pass the requisite QAC processes are approved for shipment.

Factory testing outside these parameters is considered "optional" and fall under Universal's Request For Quote (RFQ) process.

**Standard On-site Acceptance:** After delivery of the machine(s) to the customer's facility, Universal will commission the equipment to prepare it for production use by the customer. We will:

1. Inspect all items to make sure the delivery is complete against the ordered items.
2. Position the machine(s) in its final installation location. (Customer is responsible for unloading and moving the equipment on the factory floor.)
3. Level the machine(s), make the mechanical and electrical connections into the line (if required), and make all power connections. Facility must be prepared per the GS (General Specification) requirements. UIC is not responsible for any facility modifications, or for integration of / communication with any customer / 3<sup>rd</sup> party equipment or computer networking. UIC will undertake standard mechanical and electrical connections.
4. Cycle the machine(s) through its standard operational routine and prepare it for acceptance.
5. Create programs for up to two customer products, based on standard GS (General Specification) parameters and within the constraints of the "as delivered" equipment configuration.
6. Provide 4 hours of basic operator training for up to 6 persons.
7. Machine testing:
  - 7.1. If customer product was not run for factory acceptance testing and conforming\* customer product is available for on-site final acceptance testing, then our standard process defaults to preparing the machine(s) to run the conforming product for a maximum 4 hour period or 10,000 placements / insertions, while meeting the standard acceptance criteria per the tables below. Customer is responsible to make the necessary materials available for immediate use in acceptance testing.
 

\*Conforming product means product where the substrates, components, fiducials and all other characteristics fall within the machine parameters as stated in the applicable GS (General Specification).
  - 7.2. If customer product was not run for factory acceptance testing and conforming customer product is not available, then our standard acceptance process defaults to dry cycling the machine(s) for four (4) hours to demonstrate operation and complete final acceptance testing.
  - 7.3. If customer specific product was run during factory testing (conforming or non-conforming), then our standard acceptance process includes preparing the machine(s) to run that same product, and running it for a maximum 4 hour period or 10,000 placements / insertions for that product, while meeting the performance standards per the below tables. Customer is responsible to make the necessary product materials available on-site for immediate use in acceptance testing.
  - 7.4. If Universal provided acceptance materials are ordered for final acceptance testing via a Request For Quote (RFQ), then our standard process defaults to running the acceptance to demonstrate the machine(s) meets the stated operational capabilities per the GS (General Specification).
  - 7.5. If any process is found to be outside acceptable performance parameters, testing is halted, the root cause of the failure is determined and corrected, and testing is restarted.
8. Upon successful completion of the above, the machine(s) will have met the final acceptance criteria. Customer will be asked to sign off on our Customer Service Report, acknowledging this milestone has been achieved.
9. As described in the Terms and Conditions of Sale document, any use of product for purposes other than inspection and test shall constitute acceptance.

Note: Acceptance testing outside these standard parameters must be processed through Universal's RFQ process, and will result in additional cost and schedule.

**Minimum acceptance levels - Core Machines**

**Insertion Mount**

Prod Code	Universal Facility		Customer Facility	
	Insertions	DPM	Insertions	DPM
2596C	10,000	200	94,000	250
3785C	Fact	--	Fact	--
	Quote		Quote	
6241F	25,500	200	4 Hr Run	*200
6292C	42,500	150	4 Hr Run	*150
6293C	40,500	75	4 Hr Run	*75
6380 (Dual Span)	20,500	300	4 Hr Run	*300
6380 (Triple Span)	20,500	400	4 Hr Run	*400
6683C	22,500	75	4 Hr Run	*75
6687C	24,500	150	4 Hr Run	*105

Intrinsic Availability = 95%

DPM = Defects Per Million

\*DPM applies only to components and boards conforming to UIC design guideline GS 354.

**Surface Mount**

Universal Facility			Customer Facility		
Prod Code	Placements	Placement DPM	Placements	Placement DPM	IA
7A	5000	50	4 Hr Run	50	98%
687B	5000	50	4 Hr Run	50	98%
4699	Fact Quote	Fact Quote	Fact Quote	Fact Quote	--
4982	6850	50	4 Hr Run	50	98%
4983A	13600	100	4 Hr Run	100	98%
4984B	6850	50	4 Hr Run	50	98%
4797 L/S/B/	27,500	100	4 Hr Run	100	98%
X/R	5000	50	4 Hr Run	50	98%
4988	6850	75	4 Hr Run	75	98%
4990	13,600	75	4 Hr Run	75	98%
5588A	27,500	50	4 Hr Run	50	98%
5685	Fact Quote	Fact Quote	Fact Quote	Fact Quote	--
5785	Fact Quote	Fact Quote	Fact Quote	Fact Quote	--

Intrinsic Availability = IA

DPM = Defects Per Million

**Line Level Software Products**

Prod Code	Universal Facility		Customer Facility		DPM	IA
	Performance		Performance			
8684X	Fact	Note 1	Fact	Note 1	N/A	98%
	Quote		Quote			

Notes:

1. Application and configuration dependant.



## Optional acceptance testing scenarios requiring Request For Quote (RFQ):

**Optional factory acceptance at Universal** (Factory acceptances void all published machine lead times):

1. **Factory acceptance testing using customer specific product:** In addition to the standard QAC process, the customer may request a demonstration of the machine's capability to produce a specific circuit assembly product. If this is requested by the customer, specific details regarding product design, quantity to be run, schedule for delivery of substrates, components, CAD and BOM files, etc. to Universal, and other relevant factors, must be agreed prior to the time of order placement. Please note:
  - 1.1. These activities are outside the scope of standard factory QAC, and will result in an additional charge to the customer and additional time to ship.
  - 1.2. Customer provided product (boards and components) that fall outside the stated GS (General Specification) parameters may result in additional cost (and schedule) to configure the machine for the specific product (change to the customer's purchase order).
  - 1.3. Customer specific product that is run in the Universal factory will also be used for Final Acceptance Testing at the customer's site. Deviations to this must be processed through a separate RFQ process, at additional cost.
  - 1.4. If any process is found to be outside acceptable performance parameters, testing is halted, the root cause of the failure is determined and corrected, and testing is restarted
2. **Factory acceptance testing using Universal supplied acceptance material:** If the customer does not have specific product to run, but still wants to witness its machine in an operating mode before it leaves the factory, Universal may be asked to provide a quotation for an acceptance material that can be used to demonstrate the standard placement or insertion capabilities of the machine. (If these optional acceptance materials are used for factory acceptance, then additional materials and lead time will be required to demonstrate the same operational capabilities during final acceptance testing at the customer's site.) The decision to proceed with the acceptance material purchase must be made prior to the time of order placement. Delivery lead times and cost will be affected.

**Optional on-site final acceptance testing.** Any on-site acceptance testing that is outside the standard parameters defined above requires a Request For Quote (RFQ). This may include, but is not limited to, the following scenarios:

1. Extended acceptance testing to include set-up and running of additional customer products (more than one); longer test runs for products; creation of additional pattern programs (more than two), etc.
2. Any situation where the customer wants to run non-conforming product on-site, and Universal has not been made aware of and been given complete product definition prior to the time of order placement. The RFQ may result in recommended changes to the machine configuration, accessory equipment, as well as time and material for supporting the additional acceptance testing.
3. Any non-standard testing scenario not covered above.
4. If any process is found to be outside acceptable performance parameters, testing is halted, the root cause of the failure is determined and corrected, and testing is restarted

Any non-standard acceptance testing activities that were not defined / quoted at the time of order placement are outside the scope of the original order, and payment for delivered equipment is expected based on the standard acceptance test processes outlined above. Payment for the additional (RFQ) activities shall be made per separate agreement between Universal and the customer.

**System Acceptance Testing** - System acceptances are available on a Request For Quote (RFQ) basis. Due to the logistics associated with assembling a system, it is very important to give consideration to order cycle timing. Universal is not responsible for the installation and/or integration, or operation, of non-Universal brand equipment included in the system. Universal will cooperate with all other vendors to provide necessary electrical, mechanical and software handshake information to facilitate total system installation and testing.

### I. Factory Acceptance Option One

System acceptance tests may be designed to validate the operation of the equipment as an assembly system. Core machines within a system will have individually completed the Core Machine Acceptance tests and as such, these tests are not repeated as part of the standard system procedure.

1. Operational walk through and visual inspection.
  - a. Visual inspection of all equipment.
2. Capability test of the material handling system.
  - a. The printed circuit board (PCB) transfer system is tested by performing a board "pass through" run.
    - I. Quantity of boards transferred is dependent on size and complexity of system. Minimum quantity is 100. The acceptance criteria is 100% reliable transfer of the PCB's (no PCB jams, miss-locations or dropped boards).

### II. Factory Acceptance Option Two

1. Capability test on the assembly system using UIC material.
  - a. Through Hole Assembly System
    - I. Assemble 100 PCB's on the system

- a. Populated PCB's are examined for part insertions, clinch angles, lead lengths, component stability and DPM level.
  
- b. Surface Mount Assembly System
  - I. Assemble two PCB's on the system, using conforming customer material. Applicable sections (a-g) are performed.
    - a. Verify placement accuracy (relative to pad location and coverage) complies with published machine specifications. \*
      - Print solder paste on five sample boards. (customer screens and paste required)
    - b. Verify print consistency and accuracy complies with specifications for the screen printer.
    - c. Apply adhesive dots to two sample PCB's.\*
      - Verify dot consistency and accuracy complies with published specifications.
    - d. Monitor temperature profiles from the process oven.
      - Verify required profile temperatures are maintained throughout the process.
    - e. Assemble two sample PCB's on the system.
      - Verify system performance to achieve baseline for final acceptance run.
    - f. Perform a 100 PCB assembly run.
      - Verify machine performance and availability complies with machine specification.
      - Compare system throughout rate with pre-established estimate.
    - g. The acceptance criteria for placement reliability are based on the individual DPM specifications on a per machine basis.

III. Field Acceptance, On-Site at Customer's Facility

On-site customer acceptances for systems will follow the same outline as the Factory Acceptance test for systems.

IV. Special Products/OFA Acceptance Testing

Acceptance criteria for all special products or custom engineered solutions are defined at the time of quotation. Unless otherwise specified, customer supplied materials are required for machine setup, debug and acceptance for special applications.

- Accuracy verification methodology to be defined during the RFQ process, otherwise defaulting to 75% part to pad placement. Alternatives include MMI or CeTaQ as defined at time of quotation.

**END OF DOCUMENT**

---

## **Field Acceptance Kit**

---

The field acceptance kit includes the parts see in the following table. This kit is intended for use in the absence of customer supplied boards and components. This kit is designed to accommodate FlexJet, InLine 4, and Lightning head equipped machines whether single beam or dual beam. This kit requires an RFQ.

NQAP Board
1206 Capacitor
1206 Resistor
0402 Capacitor
0402 Resistor
0603 Capacitor
0603 Resistor
0805 Capacitor
0805 resistor
Resistor Network
SOT23
SOT89
SSOP8
QFP100
Double Sided Tape

## Contact Information

[www.uic.com](http://www.uic.com)

email: [universal@uic.com](mailto:universal@uic.com)

### AMERICAS

Tel. 1-800-432-2607 or

Tel. +1-607-779-7522

### ASIA

Tel. +65-6281-0991

### CHINA

Tel. +86-755-2686-0160

### EUROPE

Tel. +36-23-445500

©2005 Universal Instruments Corporation.

All rights reserved.

All specifications are subject to change.